

Light Environment Model for Testing Small-Sized Objects by Luminance Method*

Mateusz POLAR¹, Krzysztof TERESZKIEWICZ¹, Agnieszka GALA-BLADZINSKA²,
Henryk WACHTA³ and Łukasz KULIG¹

¹Rzeszow University of Technology, Department of Computer Engineering in
Management, Al. Powstancow Warszawy 12, 35-959 Rzeszow, Poland

²University of Rzeszow, Institute of Medical Sciences,
Department of Nephrology and Endocrinology, ul. Warzywna 1A, 35-310 Rzeszow

³Rzeszow University of Technology, Department of Power Electronics and
Power Engineering, ul. Wincentego Pola 2, 35-959 Rzeszow, Poland

ORCID: 0009-0006-1915-2612

ORCID: 0000-0001-6617-0852

ORCID: 0000-0001-6198-4128

ORCID: 0000-0001-8568-3709

Correspondence should be addressed to: Mateusz POLAR, m.polar@prz.edu.pl

* Presented at the 44th IBIMA International Conference, 27-28 November 2024 Granada, Spain

Abstract

This paper addresses issues related to the measurement method and the structure of the design of a universal measurement environment using a luminance meter. Work with instructions for preparing a luminance measurement station in any office space and the theory of its use. The analysis of the source resources showed that there is no comprehensive presentation of information on the conditions for carrying out measurements of the luminance distribution on the surface of small-sized objects and dedicated hardware and software for these measurements. Hence, the aim of the work was to review the conditions that shape the accuracy of measurements of the surface luminance distribution on small-sized objects. It has been shown that the key element of the measuring station, which is the matrix image recording head, allows for the recording of high-resolution images without the need to convert them. As a result, no additional identification errors of the luminance distribution on the tested surface are generated. This is part of a theoretical and practical approach to making measurements of small objects using the luminance method.

Keywords: luminance, luminance measurement, matrix meter, test station

Introduction

The measurement room has not been precisely selected and described among the studies and publications using the luminance method to analyse samples from many areas of science. The purpose of the research undertaken was to evaluate the applicability of the luminance method in the area of universal use for the analysis of various types of radiant heaters in a fixed measurement environment. The work should demonstrate the high utility of the luminance method in the study of the selected material, including: the speed of measurement (measurement time of 10 minutes), the relatively low cost of building a measurement station (the entire cost includes the luminance matrix meter, software and computer), virtually cost-free measurement, the absence of multi-step

image processing generating image analysis errors, the ease of measurement due to the implementation of an uncomplicated method.

Based on an analysis of the literature and the existing knowledge of the lighting subject matter, it was concluded that the luminance measurement room must have constant lighting parameters. The result of the work presented in the article is the design of a universal measuring station for the analysis of luminance on the surface of test objects.

Literature Review

The method of analysing luminance distribution by means of matrix luminance meter measurements is used in many engineering fields. The primary area of application is where artificial light sources are essential and our safety depends on them, i.e. road and tunnel lighting, traffic signals or emergency lighting. In these areas, luminance measurement apparatus is used to adjust pavement lighting and areas affecting visibility in such a way that they do not cause discomfort to the user and realistically improve visibility. Currently, at the stage of designing new roads and tunnels or upgrading existing ones, the value of the average luminance of the pavement is a mandatory parameter for the correct implementation of the project. The values of this parameter are defined in the PN-EN 13201-2:2007 standard. [Baxant 2016, Chrzanowicz et al. 2014, Słomiński 2018, Żagan,2021]



Figure 1. Example of road luminance measurement with a luminance matrix meter [Chrzanowicz et al. 2014].

An example of the practical application of luminance distribution is illustrated in Figure 1, which shows luminance analysis in the measurement of road lighting parameters. This is an example of the most popular use of matrix meters. A screenshot from the software shows the road in pseudocolors, indicating where the carriageway has the lowest and highest luminance values. The use of this type of analysis is essential to determine the lighting conditions in a given case, as the result is affected by many factors such as the environment, pavement wear and additional light sources [Burkhardt et al. 1984, Ketkar et al. 2020, Shi et al. 2021, Standard PN-EN 12464-1:2012, Standard PN-EN 13201-2:2007].

Road lighting is divided into pavement lighting and illumination of conflict zones. Pedestrian crossings is one of the conflict zones. They are particularly important because motorized traffic and pedestrian traffic combine here, making it extremely important to illuminate this section. In this case, the use of a luminance matrix meter makes it possible to study the vertical illuminance in the pedestrian crossing space and analyse the contrasts, resulting in improved traffic safety [Kim 2014, Sawicki 2019, Tomczuk 2012].

The second main area of use of the analysis of luminance distribution on surveyed surfaces is illumination. In this field, which mainly involves the nighttime decorative display of architectural objects, the use of a luminance matrix meter allows the design assumptions to be verified against the luminance levels actually obtained on the facades of the object [Wachta et al. 2019].

Another area where luminance meters are used is in the general analysis of light sources of luminaires or car headlights. These are areas where the effect of light on the viewer or the environment is studied, e.g., light emission by advertising banners or illuminated objects, and the study of the effect of light emission by digital

screens. With the appropriate setting of the matrix meter, the luminance distribution over the entire surface of the test object or single LED can be determined. In addition to the luminance distribution, one can observe its gradient, the dependence of luminance change on the angle of observation, the distribution of the luminescence pattern of individual pixels, or even determine the point with the highest temperature, based on observation of the point with maximum luminance. These issues are very much related in terms of the analysis of the study of glare and contrasts, which can negatively affect humans by causing disturbances in the natural cycle of life and cause unpleasant effects during daily functioning [Czyżewski 2019, Ekrias et al. 2004, Legierski et al. 2018, Zalesińska 2017].

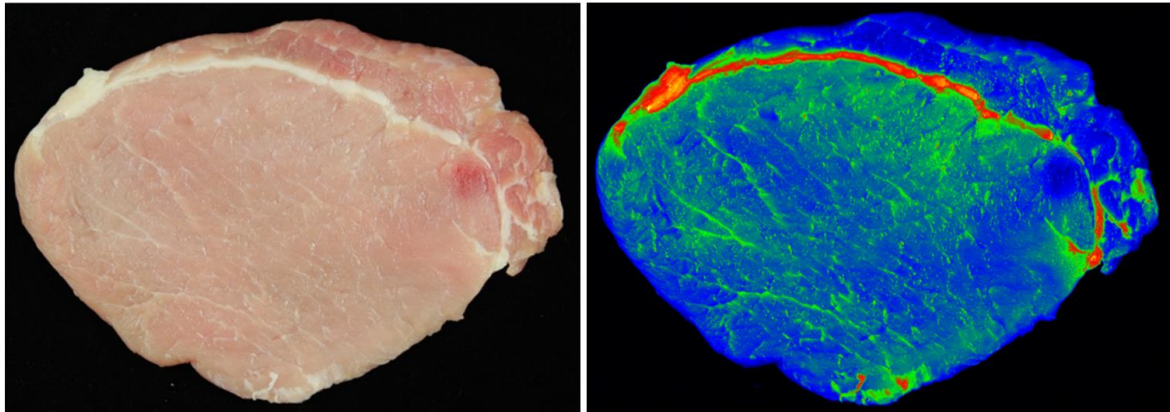

Figure 2. An example of using luminance analysis to check the fat content of a meat sample [Wachta 2022]

Also, scientific areas related to food testing rely on the luminance method. Figure 2 shows the actual image and the image of the surface luminance distribution used to analyze the fat content in the longissimus dorsi muscle sample. With the information obtained in the measurement results, it is possible to define the quality of the meat and, based on this, assign it to the appropriate class or even reject it. In addition to meat testing, luminance meters were used in analysing the freshness gradation of vegetables and fruit. In some cases, it was possible to classify whether the test sample was already at the stage of getting off and only suitable for disposal. [Takemoto et al. 2022, Wada et al. 2019, Wada et al. 2013, Wachta et al. 2022].

The described use of luminance meters presents a wide range of light influence in many fields, indicating how versatile the method of luminance distribution analysis is. On this basis, the application of the luminance method for the study of materials that are radiant or reflective elements can become an alternative to existing methods for analysing the properties of the tested materials.

Mathematical representation of luminance measurements

At the heart of the application of the image analysis method is the use of luminance, which is a photometric value that determines the ratio of the luminosity of the analysed surface of a luminous, reflective object to the area of the apparent surface of that element. Luminance is defined in units of candelas per square meter. This phenomenon is performed by the reflection of light from a reflective surface in a Lambertian (light incident on a porous material reflects and scatters from it) or Lambertian-like manner. Thus, assuming that the surface of the tissue sample is a secondary Lambert radiator, it can be assumed that within the solid angle of Ω steradians, each of the light-reflecting elements has equal luminance (Figure 3). [Filipek et al. 2017, Żagan 2018, Żagan 2022].

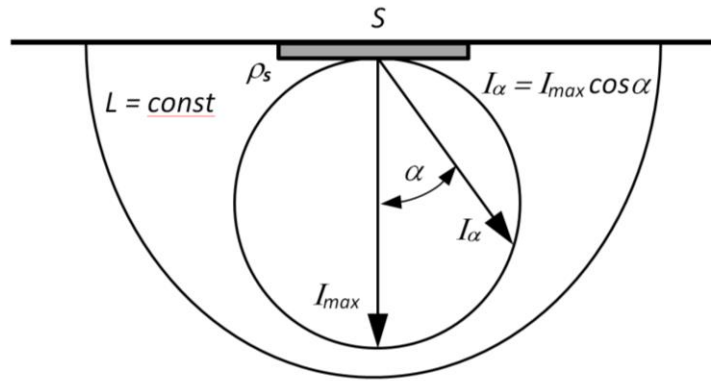

Figure 3. Characteristics of Lambertian reflection from an elementary surface S [Standard PN-EN 12464-1:2012]

Analytically the luminance for an elementary surface S can be written with the following formula:

$$L_{\alpha} = \frac{I_{\alpha}}{S \cos \alpha} = \text{const} \quad (1)$$

Where at formula 1 L_{α} stands for the luminance of an elementary surface S, I_{α} is the luminous intensity of an elementary surface S in the direction α and S is an elementary surface that reflects light.

The aforementioned formula is crucial in the application of the luminance method, since the luminance of any surface element depends on the amount of light incident on that surface and how much light that surface reflects. Providing constant (homogeneous) illumination of a given surface, its brightness will depend only on the scale of light reflection. This scale depends on the colour and type of porosity of the material [Filipek et al. 2017, Źagan 2018, Źagan 2022].

It follows from the formula that the luminance value L (brightness of the illuminated surface) of a diffusely reflective surface is related to the light intensity E (the amount of light incident on a given surface) on that surface and the reflectance of that surface (the ability of the surface to partially absorb and reflect light incident on that surface). Having at one's disposal, as a special case, a set of elementary surfaces with different reflectance (e.g., associated with them different colour temperatures – colour) and a constant illuminance – the amount of light incident on a given surface, one obtains a function of the direct relationship between the colour temperature of individual elementary surfaces [Filipek et al. 2017, Źagan 2018, Źagan 2022].

In other words, the luminance method consists in obtaining, as a result of taking a photo of a given material surface, another image of this surface, which illustrates its brightness distribution in the form of a point set (one measurement point corresponds to one pixel with a diameter of about 0.2 mm. Thus, the luminance method can only include surface analysis of the sample. If there are local changes in colour or porosity within this surface, then illuminating this surface with uniform light will give an image of this illuminated surface as a distribution of the set of brightness (luminance) of individual zones of this surface (each zone corresponds to an elementary field of pixel size).

The construction of the measurement station should give the possibility of obtaining uniform illumination on the sample, and this is a prerequisite for the useful application of the method, knowing that changes in the brightness of the sample zones are solely due to changes in the colour or porosity of the sample zones, and not to non-uniform illumination of the sample.

Measurement station concept

The goal of this stage was to develop a concept for a station with a light environment in which it will be possible to analyse, under constant lighting conditions, the distribution of luminance on computational surfaces.

The measurement location shown in Figure 4 consists of an enclosed room, illuminated by electric light with appropriately selected reflectance from the walls and ceiling (1), a measuring table (3) coated with a black material (4) performing Lambertian reflection (a material that absorbs the incident light directly from the luminaries and indirectly from the ceiling and walls), a set of four luminaries (2) performing direct or indirect illumination to the measuring station (5), a small-sized luminance meter head equipped with a high-resolution CMOS sensor (6), a tripod mounting the head centrally over the measuring table (7), ensuring stable positioning and precise positioning of the measuring head over the geometric centre of the surface of the measuring table, an optical cable (8) connecting the luminance measuring device with the software on the computer (9), and a table (10) on which the computer set is located.

Measurement of the luminance distribution on the test surface (5) is carried out on a rectangular plane of the measuring table (3) with a height that allows precise placement of the test surface (5). A calculation surface (3) is placed on the black backing material.

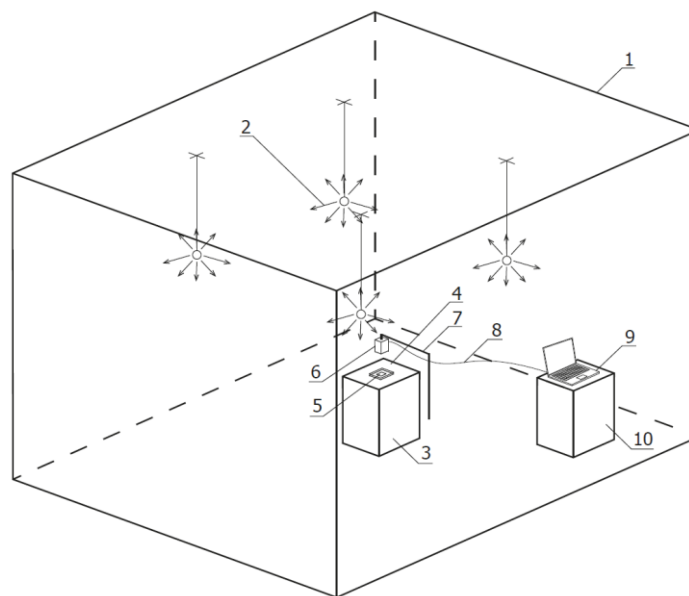

Figure 4. Conceptual model of test station for luminance distribution measurements [own work]

Legend: 1 – ceiling, 2 – four luminaries, 3 – measuring table, 4 – black material, 5 – measuring surface, 6 – small-size head of matrix luminance meter, 7 – head mounting tripod, 8 – optical cable, 9 – computer, 10 – table.

Research methodology

Specialized software for calculating light situations, Dialux Evo, developed by the German company DIAL, was used for the simulation. It is the most popular software in the lighting industry that allows the calculation of lighting parameters of indoor objects and outdoor areas with the possibility of visualization. Thanks to the advanced algorithms implemented in the Dialux Evo environment, it was possible to map the test station shown in Figure 4, taking into account all the parameters taken into account at the station concept stage.

The room chosen for the measurement room is a square area of more than 30 square meters. The reflection coefficients for the floor, walls and ceiling are 0.3; 0.5 and 0.7, respectively. These coefficients were selected based on Table 1, included in the PN-EN 12464-1:2012 standard. The values used in the project are at the lower limits of the ranges, due to the assumption that we are considering the most severe reflective conditions acceptable by the standard [Żagan 2022].

Table 1. Recommending values for surface reflectance in interiors [Standard PN-EN 12464-1:2012]

Area	Reflectance value
Ceiling	0.7 – 0.9
Walls	0.5 – 0.8
Floor	0.2 – 0.4

The height of the measurement room is 2.8 meters, which is the standard height of office rooms constructed under current construction standards. In order to reduce the influence of reflections from other surfaces, all elements used in the simulation were centred (measuring table) or positioned at symmetrical distances from the centre of the room (luminaries).

The light points used in the simulation of the measurement environment are high-end designs with reflective optical systems to reduce glare. The optics of the lamps used, represented by the photometric solids (Figure 5), are symmetrical. The reason for this selection was to maintain static values over as wide an area as possible. In this case, moving the measurement plane relative to the centre of the room will have a negligible effect on the results of uniformity and illuminance.

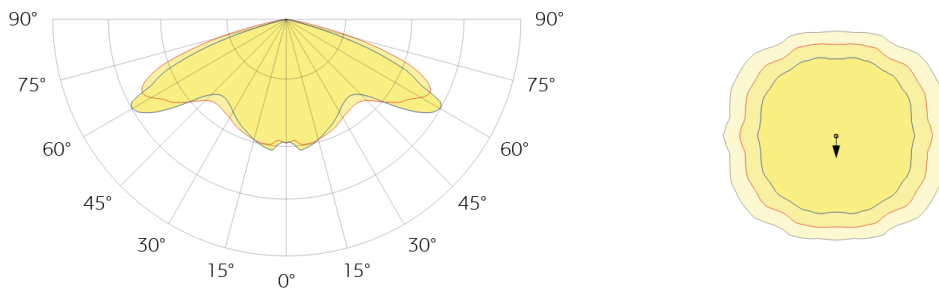

Figure 5. Graphic rearrangement of the light distribution curve and luminaire contours used in the simulation of the measurement room [7]

All the light sources used are characterized by the same values of light parameters. Each luminaire generates 21.5 watts of power consumption and 1960 lumens of luminous flux, resulting in an efficiency of 91 lumens per watt. The selected colour temperature of the light is 4000 Kelvin. This value generates better luminous efficiency relative to warmer colour temperatures and, thanks to the neutrality of the colour, allows greater focus when working in the room.

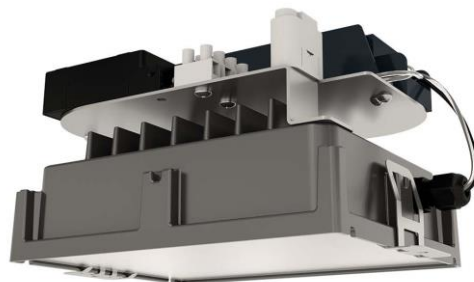

Figure 6. Visualization of the luminaire used [<http://www.aecillumination.com/Fixture/iBox>]

Thanks to the specialized design (Figure 6), the selected luminaire has an IP66 sealing factor and IK09 mechanical strength rating. The use of frosted glass increases the uniformity of light distribution by reducing the amplitude of distribution values in given solid angle ranges. An additional feature of the lamps used is the ability to adjust the luminous flux by controlling it with voltage regulation.

Lighting the room with light directed downward was intended to assess the uniformity of lighting at the test station. Simulations were performed for two sizes of the design field – 20x20 cm and 80x80 cm. The reason why two surfaces were determined is to analyse different sample sizes. Thanks to this, the test station demonstrates universal performance in terms of analysing any shape of the tested elements without the need for structural changes to the test station while keeping the light parameters constant. In order to carry out the measurements correctly, it was necessary to determine the number of measurement points on the analysed computational planes. The EN 12464-1:2012 standard recommends using a minimum number of measurement points depending on the size of the area. One way to determine the number of measurement points is to calculate them based on the values in Table 2. [Standard PN-EN 12464-1:2012]

Table 2. Summary of the recommended number of grid measurement points relative to the size of the measurement field [Standard PN-EN 12464-1:2012]

Area length [m]	Maximum distance between points [m]	Minimum number of grid points
0.40	0.15	3
0.60	0.20	3
1.00	0.20	5
2.00	0.30	6
5.00	0.60	8
10.00	1.00	10
25.00	2.00	12
50.00	3.00	17
100.00	5.00	20

Given the length of the selected design field of 80 centimetres was assigned the nearest possible value from the table. Then, to get the correct number of measurement points in the selected area, multiply the selected value from the table for the length of the area by the number of points assigned to the width of that area. In the case of the variants shown in the simulations, the area is square-shaped, resulting in the equality of the length and width of the area, making the total number of measurement points the product of two values of 5 and equal to 25 points.

The final step is to deploy the luminance apparatus to perform measurements in the test environment created earlier. TechnoTeam's LMK model is the luminance meter used to test objects in the measurement room is (Figure 7).



Figure 7. Photometric head with matrix image recorder used in the study

[https://www.technoteam.de/products/imaging_photometer_colorimeter/lmk_6_color/index_eng.html
(09.08.2023)]

The luminance measuring device was equipped with a fixed-aperture lens and a focal length of 8 millimetres. Thanks to the optoelectronic system used in the meter to extend the path of the light rays, it is possible to test small areas. Due to the compact size of the photometric head, placing it above the measurement field does not generate additional shading of the test area.

To analyse the captured images by the luminance meter apparatus, software called LMK Software by TechnoTeam was used, which performs the functionalities of testing with high accuracy the luminance distribution on the sample surface in a defined area, testing the luminance distribution in defined areas of maximum and minimum luminance, testing with high accuracy the size of the surface area for a defined luminance range, and testing the location on the sample surface of zones of a given luminance band.

Based on the developed methodology, the placement of samples for testing meets the assumptions of repeatability of measurements, due to the stability of light conditions and structural elements. The station along with the measurement method is performed in such a way that the implementation of the presented solutions in the real environment is simple and universal. The matrix meter apparatus described in the methodology is an example application of this type of equipment. In place of the LMK head it is possible to use other luminance measurement equipment that meets the same criteria.

Summary

The proposed method, apart from identifying luminance based on the chromaticity phenomenon, enables the assessment of the porosity features of the material surface. This allows the identification of luminance distribution using two indicators: colour and reflective surface features related to its degree of porosity.

The measuring station can be used in interiors with functional general lighting, without the need to supplement the measuring station components with dedicated lighting. The key element of the measuring station, which is the matrix image recording head, allows for the recording of high-resolution images without the need to convert them. As a result, no additional identification errors of the luminance distribution on the tested surface are generated.

The station has great development potential with a step change in image recording technology.

Literature

- Baxant, P., Skoda, T., Szumec, S. (2016), "Contrast analysis in lighting technology". IEEE Lighting Conference of the Visegrad Countries (Lumen V4). Karpacz.
- Burkhardt, D.A., Gottesman, J., Kersten, D., and Legge, G.E. (1984), "Symmetry and constancy in the perception of negative and positive luminance contrast". Dept. of Psychology, University of Minnesota. <https://doi.org/10.1364/JOSAA.1.000309>
- Chrzanowicz, M., Tomczuk, P. (2014), „Analiza rozkładu luminancji wybranego odcinka drogi dwujezdniowej oświetlonego przez system latarni ulicznych”. Warsaw University of Technology.
- Czyżewski, D. (2019), "Comparison of luminance distribution on the lighting surface of power LEDs", Warsaw.
- Ekrias, A., Eloholma, M., Halonen, L., Song, X., Zhang, X., Wen, Y. (2004), "Road lighting and headlights: Luminance measurements and automobile lighting simulations". Helsinki University of Technology. <https://doi.org/10.1016/j.buildenv.2007.01.017>
- Filipek, M., Cirynger, J. (2017), „Badanie oświetlenia”. Krakow.
- <http://www.aecillumination.com/Fixture/iBox> (10.05.2023)
- https://www.technoteam.de/products/imaging_photometer_colorimeter/lmk_6_color/index_eng.html (09.08.2023)
- Ketkar, M.D., Sporar, K., Gu" r, B., Ramos-Traslosheros, G., Seifert, M., and Silies, M. (2020). "Luminance information is required for the accurate estimation of contrast in rapidly changing visual contexts". Institute of Developmental Biology and Neurobiology, Johannes Gutenberg-University. <https://doi.org/10.1016/j.cub.2019.12.038>
- Kim, G., Amina, I., Lim, H.S., Kim, J.T. (2014), "The Impact of Distance on the Accuracy of Luminance Measurement". Dept. of Architectural Engineering, Kyung Hee University. <https://doi.org/10.1016/j.egypro.2014.12.424>

- Legierski, M., Michałek, P. (2018), "Assessment of blue light retinal hazard of lamps and lights used in automotive", Warsaw University of Technology.
- Zalesińska, M. (2017), "The impact of the luminance, size and location of LED billboards on drivers' visual performance—Laboratory tests". Poznan University of Technology. <https://doi.org/10.1016/j.aap.2018.02.005>
- Sawicki D. Wolska A. Porsch T. (2019), "Glare assessment for research and development of measurement methods." Warsaw.
- Shi, L., Zhang, Y., Wang, Z., Cheng, X., Yan, H. (2021), "Luminance parameter thresholds for user visual comfort under daylight conditions from subjective responses and physiological measurements in a gymnasium". Harbin Institute of Technology. <https://doi.org/10.1016/j.buildenv.2021.108187>
- Słomiński, S. (2018), "Typical Causes of Errors During Measuring Luminance Distribution in Relation to Glare Calculations". VII Lighting Conference of the Visegrad Countries (Lumen V4).
- Standard PN-EN 12464-1:2012
- Standard PN-EN 13201-2:2007
- Takemoto, R., Koyama, K., Watanabe, T., Koseki, S., Nakamura, N. (2022), "Mathematical model for analyzing the effect of storage conditions on the visually perceived freshness of strawberries via surface luminance distribution". Hokkaido University. <https://doi.org/10.1016/j.fpsl.2022.100965>
- Tomczuk, P. (2012), "Assessment model of luminance contrast of pedestrian figure against background on pedestrian crossing". Electrical Review, R. 88 NR 3a/2012 p.104-107 SIGMA-NOT. Warsaw University of Technology.
- Wada, Y., Arce-Lopera, C., Masuda, T., Kimura, A., Dan, I., Goto, S., Tsuzuki, D., Okajima, K. (2019), "Influence of luminance distribution on the appetizingly fresh appearance of cabbage". Research Institute of Environment and Information Sciences, Yokohama National University. <https://doi.org/10.1016/j.appet.2010.01.002>
- Wada, Y., Arce-Lopera, C., Masuda, T., Kimura, A., Okajima, K. (2013), "Model of vegetable freshness perception using luminance cues". Faculty of Engineering, ICESI University. <https://doi.org/10.1016/j.foodqual.2014.06.010>
- Wachta H., Leśko M., Baran K. (2019) "The meaning of qualitative reflective features of the facade in the design of illumination of architectural objects". Melville, NY: AIP Publishing. <https://doi.org/10.1063/1.5092105>
- Wachta, H., Tereszkiewicz, K., Kulig, Ł. (2022), "Luminance surface distribution measurements applied to assessing intramuscular fat content in meat". Rzeszow University of Technology. <https://doi.org/10.1016/j.measurement.2022.110846>
- Żagan, W. (2018), „Obliczenia oświetlenia”. Warsaw University of Technology.
- Żagan, W. (2021), „Oświetlenie ulic”. Warsaw University of Technology.
- Żagan, W. (2022), „Podstawy techniki świetlnej wydanie nr 3”. Warsaw University of Technology.